

Glass Infill Systems

1) Check Contents Of Packages: Verify that all parts have arrived and that they match the packing list.

2) Gather and Identify All Posts: Use the *rail connecting block (RCB)* holes on each *post* to identify the post type:

- End posts – *RCB* holes on one side only.
- Intermediate posts – *RCB* holes on opposite sides.
- Single corner posts – *RCB* holes on adjacent sides.

3) Install Posts: Position and fasten all *posts*. The sides of the posts with *RCB* holes should be facing the adjacent *post(s)*. Be sure that the posts are plumb, in-line with one another, and spaced a **maximum** of 5 feet apart. The lag bolts must have a minimum of 3" of thread penetration into solid wood for a proper, secure post attachment; use additional wood blocking and/or longer bolts if necessary.

- *Surface mounting:* anchor each *post* using four 3/8" x 3-1/2" (or longer) *lag bolts* with *retaining washers* and *colored caps*.
- *Fascia mounting:* anchor each *post* using 3/8" x 6" (or longer) *lag bolts* with *retaining washers* and *colored end caps*. When finished, screw-on decorative *post caps* to the bottom of each *post*.

If you are mounting posts using the *stanchion mount* or *fascia bracket mount* methods, please call for additional installation details.

4) Cut & Attach Cap Rails: Cut the *cap rail* to length and then snap it into position on top of the *posts*. Be sure to attach *decorative end caps* (see step #6) to any ends that terminate against a wall face or that have limited access.

- *Butt splices:* always cut the *cap rail* at 90 degrees and center the joint over a *post*. Use a rectangular splice plate with four #8-32 x 3/4" *tech screws* to secure the joint.
- *Mitered corner joints with double corner posts:* the *cap rail* will extend past each of the corner *posts* and the actual miter joint will be unsupported. Remember to cut each *cap rail* miter at 1/2 the total corner angle (i.e. if the corner angle is 90 degrees, cut each miter at 45 degrees). Add two *splice plates* to connect and stabilize the miter joint. Each splice plate is secured with four #8 x 3/4" *tech screws*.

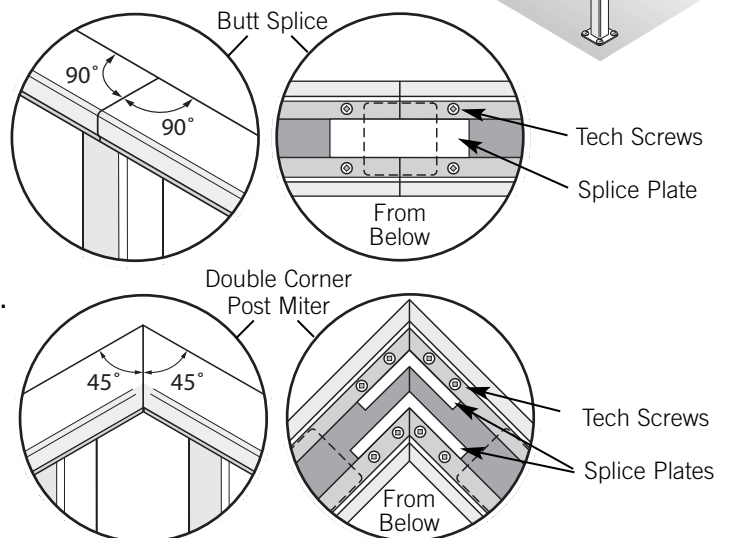
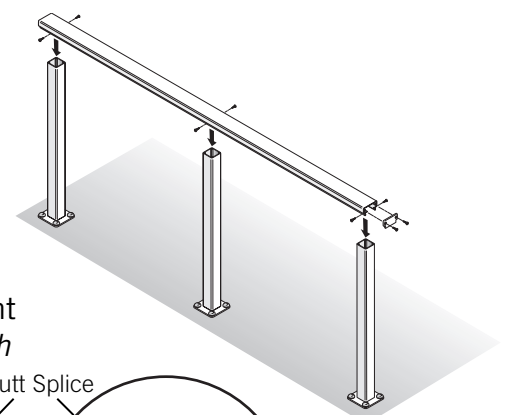
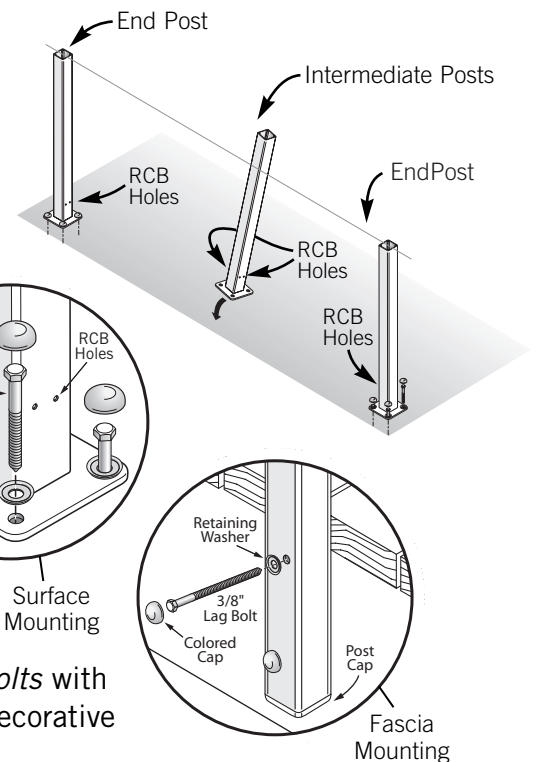

- **Mitered corner joints with single corner post:** cut each *cap rail* miter at 1/2 the total corner angle (i.e. if the corner angle is 90 degrees, cut each miter at 45 degrees) Center the joint over the corner *post*. Add one *splice plate* to connect and stabilize the miter joint; each *splice plate* is secured with four #8 x 3/4" *tech screws*. Also, on each side of the miter cut, screw a #8 x 3/4" *tech screw* through the *cap rail* flange and into the *post* face.

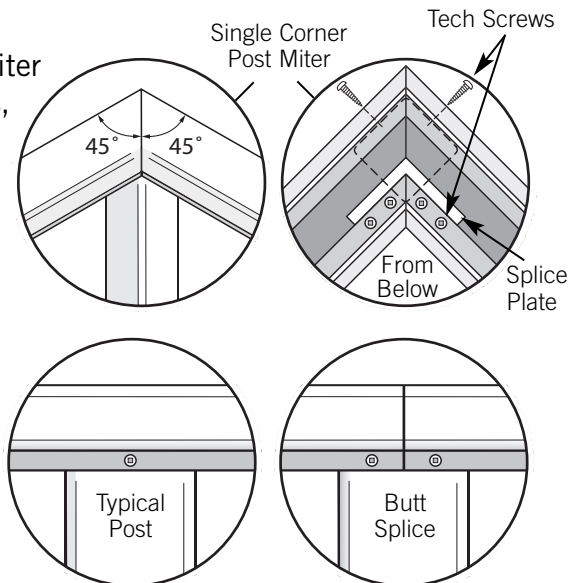

- 5) Fasten Cap Rails:** Secure the *cap rail* to each *post* using two #8 x 3/4" *tech screws* (one each side); Butt splices require four screws (two each side). Screws should run through the *cap rail* flange and into the *post* face.

- 6) Attach Decorative End Caps:** Attach the *decorative end caps* to all of the exposed *cap rail* ends using two #8 x 1" *flat head screws*.

- 7) Attach RCBs:** Locate the *rail connecting block (RCB)* holes on each *post* (these are pre-drilled except on stair rail *posts* where all the holes must be drilled in the field). Attach the *RCBs* to the posts using two #10 x 1-1/2" *SS pan head screws* provided. The *RCBs* should be mounted wings down.

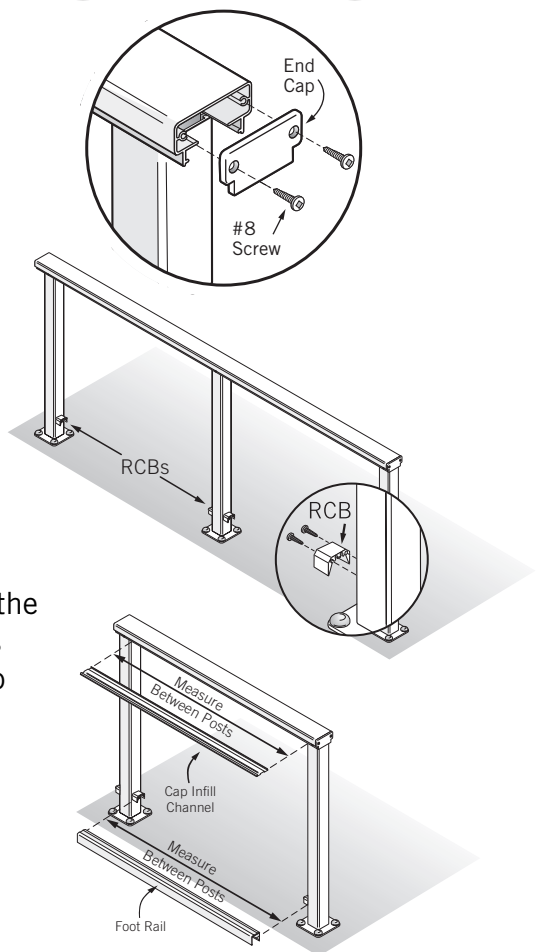

- 8) Cut Foot Rails:** Measure between each set of *posts* just above the *RCBs*. Cut the *foot rail* and the *vinyl liners* for each section no more than 1/16" shorter than your corresponding measurement. Remember, the *liner* for the *foot rail* has a slightly shallower slot than the *liner* for the *cap infill channel*. *Liners* do not have to be installed as one continuous piece; separate pieces can be butted together. Cut and press *liners* into their respective slots in the *foot rail*. Do not attach the *foot rails* to the frame at this time.

- 9) Cut Cap Infill Channels:** Measure between each set of *posts* just below the *cap rail*. Cut the *cap infill channel* and the *vinyl liner* for each section to no more than 1/16" shorter than your corresponding measurement. Remember, the *liner* for the *cap infill channel* has a slightly deeper slot than the *liner* for the *foot rail*. Cut and press *liners* into their respective slots in the *cap infill channel*.

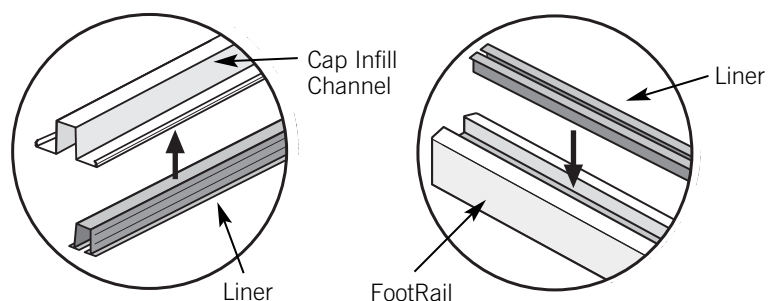

10) Install **Foot Rails and Cap Infill Channels:**

Snap the *cap infill channel* into the bottom of the *cap rail*. Slip the *foot rail* over the *RCBs* and fasten with the 8 x 3/4" *tech screws*. You may want to pre-drill these holes before attaching screws, as the wings of the *RCBs* tend to flex when pushed by a *tech screw*. Also, be sure to slightly offset opposing screw holes so that the screws don't hit one another inside the *RCB*.

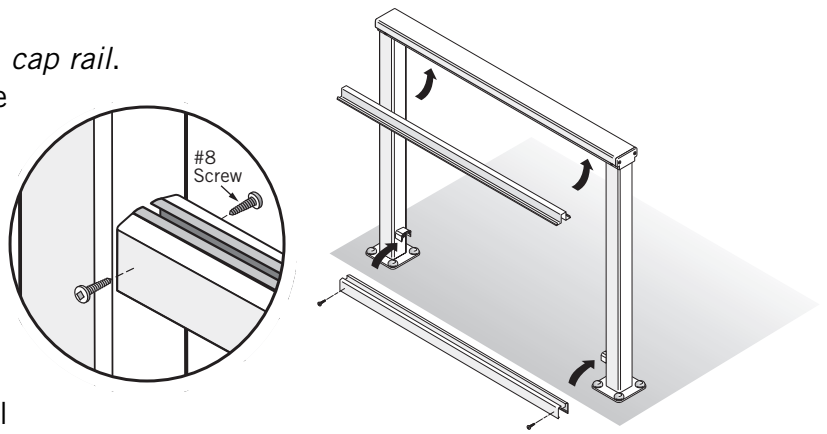

11) Measure For *Glass Panels:* Measure each infill section individually from left to right between each set of *posts* and from top to bottom between the exposed flanges of the *vinyl liners*. Do not measure from the bottoms of the inside channels of the *liners*. Take 4 measurements per panel (as shown in the illustration) in event the frame is not perfectly level or plumb. Record your measurements individually on the sheets provided.

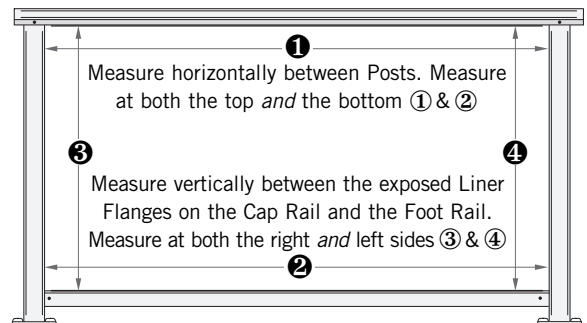

12) Install *Glass Panels:* When installing *glass panels* it is necessary to lubricate the *vinyl liners* before installation. The *glass* fits very tightly in the *liners*, and without lubrication there is a possibility of breaking a *glass panel*. Soap, silicone, WD-40® or Windex® will suffice. Holding a *glass panel* by its vertical edges insert the top edge of the *glass* as far as it will go into the *cap infill channel liner*. Then drop the bottom edge of the *glass* into the channel of the *foot rail liner* until it seats completely. Slide the *glass panel* horizontally in the *channel* to center it between the *posts*. The same procedure also applies for stairs.

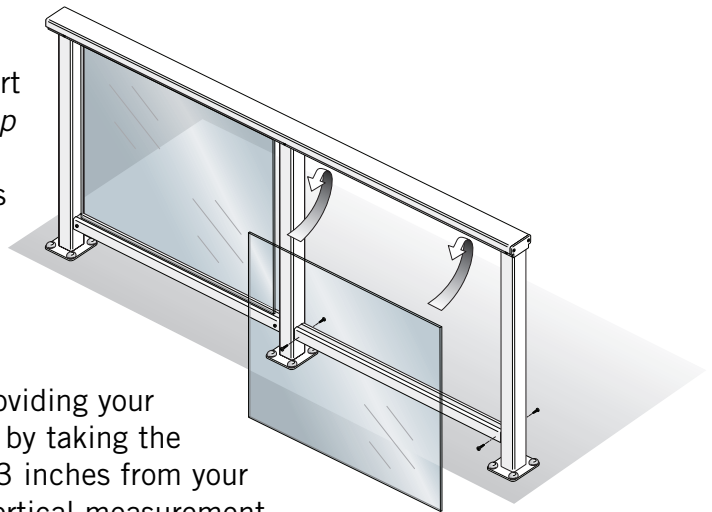

Note: Calculate Actual Glass Dimensions: If you are providing your own glass, calculate the actual glass panel dimensions by taking the measurements as described in step 11 and deducting 3 inches from your horizontal measurement and adding 3/4 inch to your vertical measurement. Be sure to have the two vertical edges of each panel ground smooth to remove the sharp edges and prevent the chance of someone cutting themselves during installation.

This completes a Glass System installation.