

Picket Systems

1) Check Contents Of Packages: Verify that all parts have arrived and that they match the packing list.

2) Gather and Identify All Posts: Use the *rail connecting block (RCB)* holes on each *post* to identify the post type:

- End posts – *RCB* holes on one side only.
- Intermediate posts – *RCB* holes on opposite sides.
- Single corner posts – *RCB* holes on adjacent sides.

3) Install Posts: Position and fasten all *posts*. The sides of the posts with *RCB* holes should be facing the adjacent *post(s)*. Be sure that the posts are plumb, in-line with one another, and spaced a **maximum** of 5 feet apart. The lag bolts must have a minimum of 3" of thread penetration into solid wood for a proper, secure post attachment; use additional wood blocking and/or longer bolts if necessary.

- *Surface mounting:* anchor each *post* using four 3/8"x 3-1/2" (or longer) *lag bolts* with *retaining washers* and *colored caps*.
- *Fascia mounting:* anchor each *post* using 3/8"x 6" (or longer) *lag bolts* with *retaining washers* and *colored end caps*. When finished, screw-on decorative *post caps* to the bottom of each *post*.

If you are mounting posts using the *stanchion mount* or *fascia bracket mount* methods, please call for additional installation details.

4) Cut & Attach Cap Rails: Cut the *cap rail* to length and then snap it into position on top of the *posts*. Be sure to attach *decorative end caps* (see step #6) to any ends that terminate against a wall face or that have limited access.

- *Butt splices:* always cut the *cap rail* at 90 degrees and center the joint over a *post*. Use a rectangular splice plate with four #8-32 x 3/4" *tech screws* to secure the joint.
- *Mitered corner joints with double corner posts:* the *cap rail* will extend past each of the corner *posts* and the actual miter joint will be unsupported. Remember to cut each *cap rail* miter at 1/2 the total corner angle (i.e. if the corner angle is 90 degrees, cut each miter at 45 degrees). Add two *splice plates* to connect and stabilize the miter joint. Each splice plate is secured with four #8 x 3/4" *tech screws*.

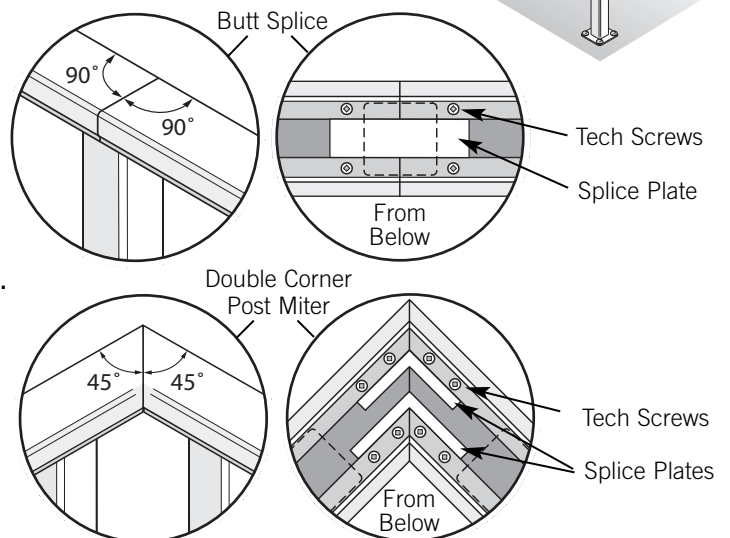
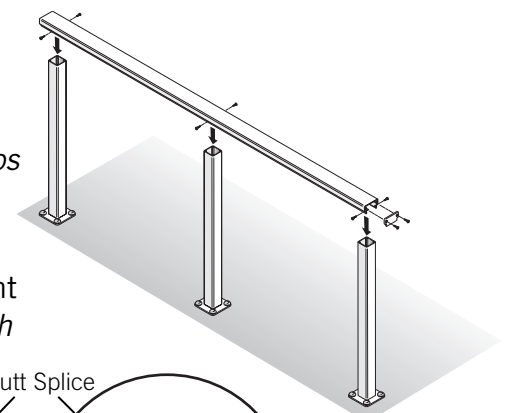
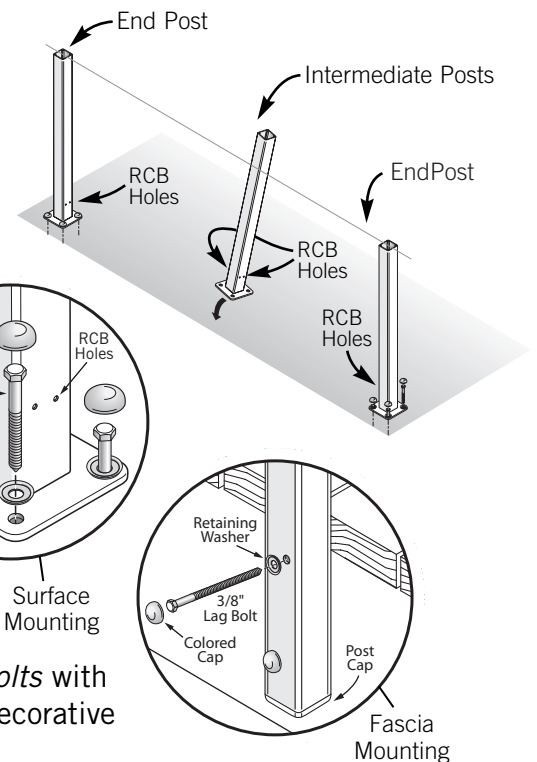

- **Mitered corner joints with single corner post:** cut each *cap rail* miter at 1/2 the total corner angle (i.e. if the corner angle is 90 degrees, cut each miter at 45 degrees) Center the joint over the corner *post*. Add one *splice plate* to connect and stabilize the miter joint; each *splice plate* is secured with four #8 x 3/4" *tech screws*. Also, on each side of the miter cut, screw a #8 x 3/4" *tech screw* through the *cap rail* flange and into the *post* face.

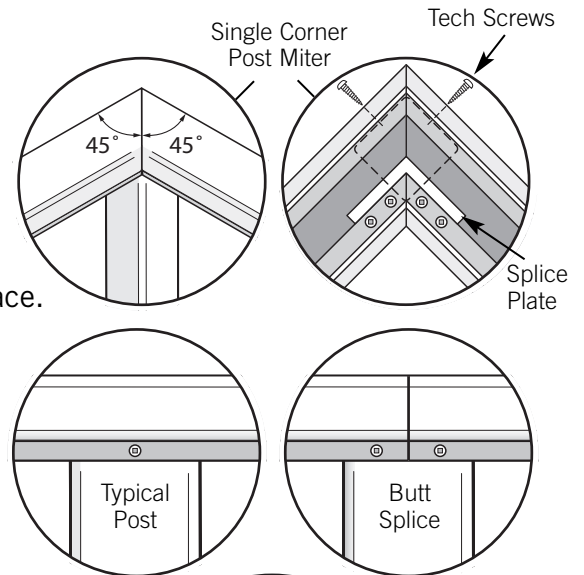

- 5) Fasten Cap Rails:** Secure the *cap rail* to each *post* using two #8 x 3/4" *tech screws* (one each side); Butt splices require four screws (two each side). Screws should run through the *cap rail* flange and into the *post* face.

- 6) Attach Decorative End Caps:** Attach the *decorative end caps* to all of the exposed *cap rail* ends using two #8 x 1" *flat head screws*.

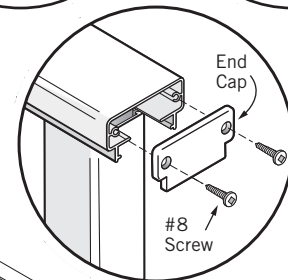

- 7) Attach RCBs:** Locate the *rail connecting block (RCB)* holes on each *post* (these are pre-drilled except on stair rail *posts* where all the holes must be drilled in the field). Attach the *RCBs* to the posts using two #10 x 1-1/2" *SS pan head screws*. The *RCBs* should be mounted wings down.

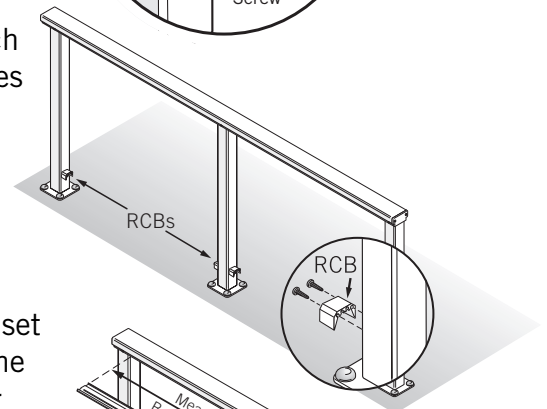

- 8) Measure Foot Rails & Cap Infill Channels:** Measure between each set of *posts* just above the *RCBs* for the *foot rail* length and just below the *cap rail* for *cap infill channel* length. Record these measurements for each infill section.

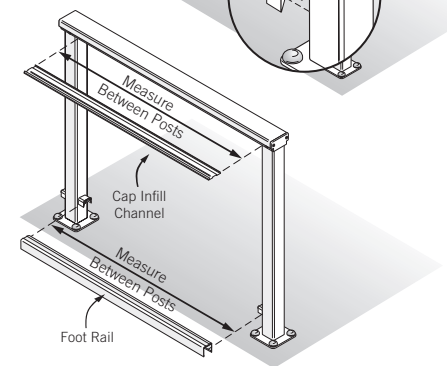

- 9) Cut Foot Rails & Cap Infill Channels:** For aluminum picket systems the *foot rails* and *cap infill channels* come with picket screw holes pre-drilled. Note that it is necessary to cut both the *foot rails* and *cap infill channels* so that when they are installed their **holes line up vertically** and the final array of *pickets* is **centered evenly between posts**. Additionally note that each *picket* has a built-in screw chase hole which is located on the inside edge of each *picket*, **not the center** of the *picket* (see diagram). Therefore, when installed, the *pickets* will not be centered over each hole but instead will be offset to one side by 1/4". Be sure to allow for this offset when planning your *foot rail* and *cap infill channel* cuts. Remembering the above notes, cut the *cap infill channel* for each section no more than 1/16" shorter than your corresponding measurements from step 8.

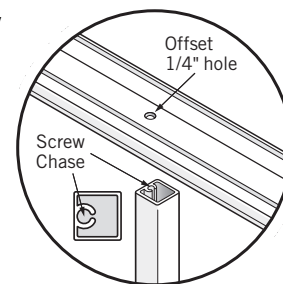

10) Assemble *Picket Panels*: Using the #10 x 5/8" SS *pan head screws*, attach *pickets* to the *cap infill channel* and then to the *foot rail* to make up a *Picket Panel* for each infill section.

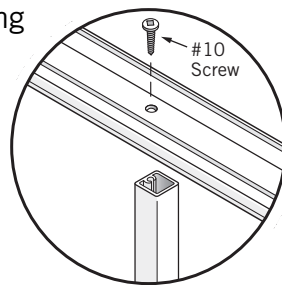

CAP INFILL CHANNEL ATTACHMENT

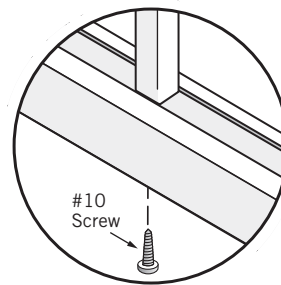

FOOT RAIL ATTACHMENT

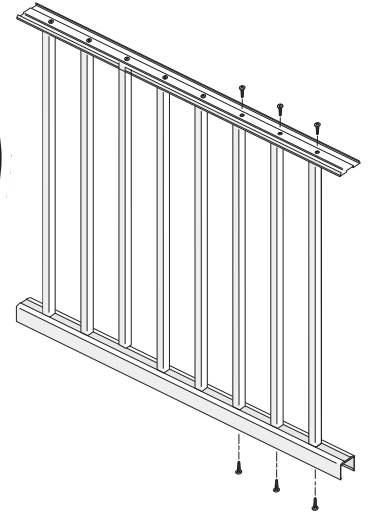

11) Install Assembled *Picket Panels*: Lift the completed *picket panels* (assembled *cap infill channel*, *foot rail* & *pickets*) into position on the frame by first tilting-in the *foot rail* on top of the *RCBs* and then rotating the top of the *picket panel* inward. The top of the *panel* should just clear the bottom of the *cap rail*. At this point you should be able to lift the entire *panel* up by the *cap infill channel* and snap it into place inside the *cap rail*. Use two #8 x 3/4" *tech screws* to fasten the *foot rail* to each *RCB*. Pre-drill these holes with a 9/64" drill bit before attaching screws, as the wings of the *RCBs* tend to flex when pushed by a *tech screw*. Also, be sure to slightly offset opposing screw holes so that the screws do not hit one another inside the *RCB*.

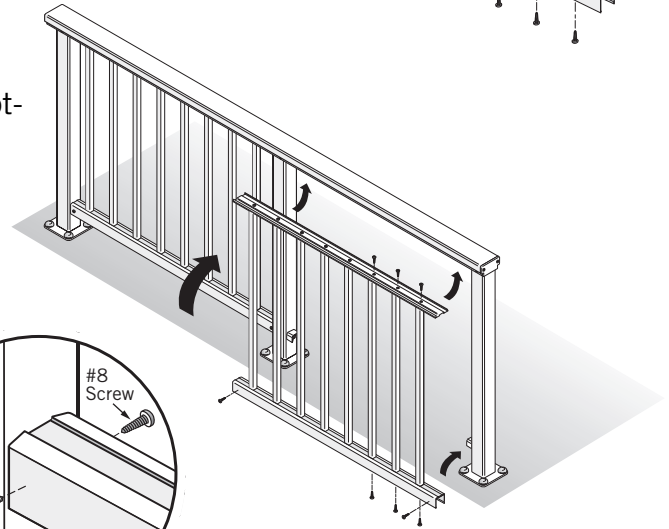
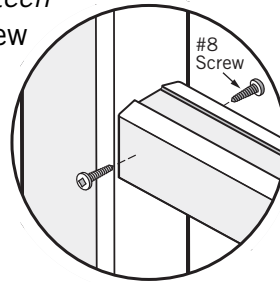

This will complete a *Picket System* assembly.